



CAD/CAM for next generation makers

SprutCAM X is a CAD/CAM software with streamlined workflow and comprehensive functionality. Compatible with any CNC machine: 3, 4 and 5 axis Mill, Lathe, Mill-turn, Swiss, MTM, EDM. Toolpath calculation is performed taking into account full machine kinematics and limitations, including collision avoidance and axis limits control.

Enjoy the power, speed and safety of a natural
easy to learn & use CNC programming workflow

Product Highlights

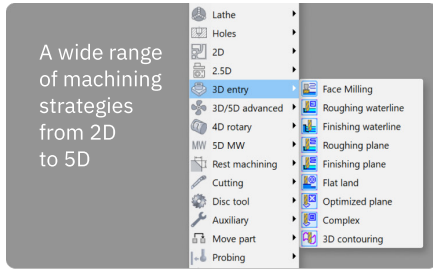

%001
→ **1 G0**
N2T2

G-code simulation and transformation to other CNC formats

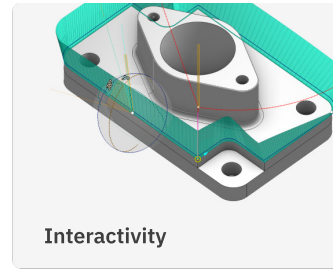

Enhanced security

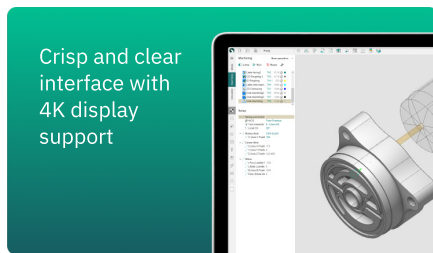
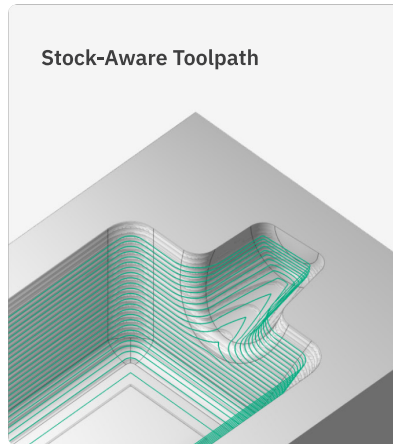
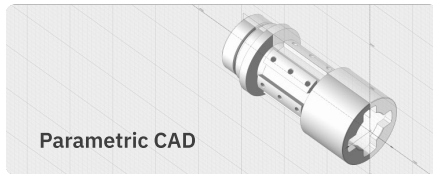

SprutCAM X CNC Machine Programming Workflow

We pioneered Machine-Aware Programming, a technology that considers the movement capabilities and limitations of machines and robots at the initial programming stage, unlike most other systems that integrate these considerations during the machining simulation stage. This eliminates the need for reprogramming and re-verification, ultimately reducing the time from project initiation to code completion.

Traditional CAM

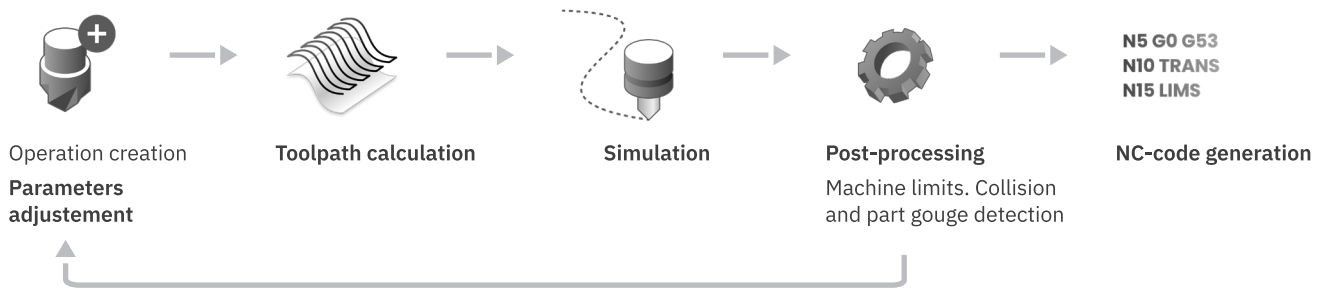

SprutCAM X



Go beyond the traditional workflow of most CAM systems

SprutCAM X Machine-Aware technology reduces programming time by 50% compared to traditional workflow

Applications

Comprehensive range of solutions for programming all types of CNC machines.

Rotary

Production of screws, blades, gear wheels, balusters

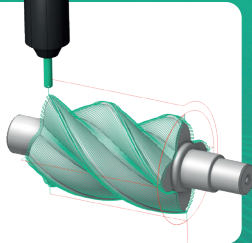

Lathe

Turning and boring, threading, trimming, drilling, reaming

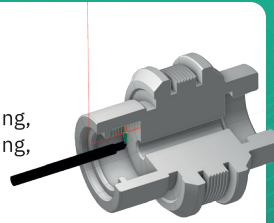

2.5x and 3x mill

Production of molds & dies and any other parts on a 3-axis milling machine

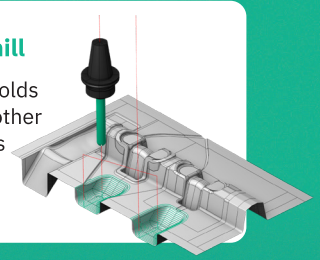

Mill-turn

Turning and milling combined in one setup

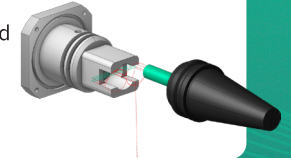

Multiaxis

Index (3+2) and simultaneous 5 axis milling. For turbine wheels, blades, port machining

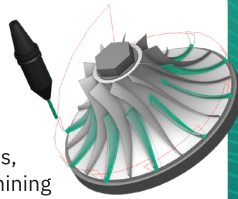

HSM and adaptive

High speed and adaptive toolpaths for quick material removal with extended tool life

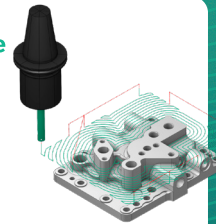

Swiss and MTM

Swiss-type machines and MTM (multi-channel machining) with synchronization

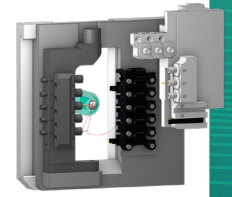

5-6D cutting

CNC programming of cutting, trimming, 6D knife cutting. Mill, laser, water, plasma, drag knife

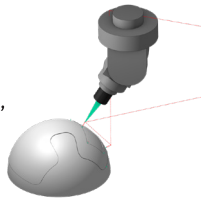

Additive and hybrid

Cladding, hybrid technology on 5-axis, mill-turn machines and robots

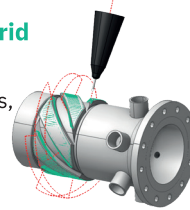

EDM

2 – 4 axis strategies for wire EDM machining

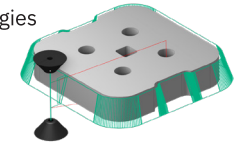

2D cutting

Programming of laser, waterjet, plasma, oxy-fuel cutting and knife cutting

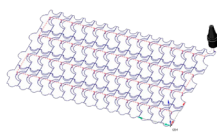

G-code based simulation

G-code verification in SpruCAM

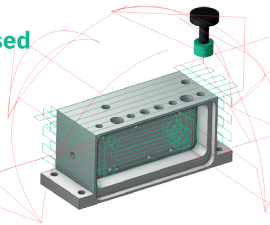

Probing cycles

Probing cycles for Milling and Lathe Machines

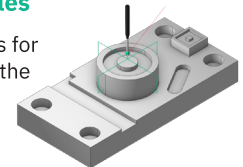

MachineMaker. Your CNC Machine digital twin

The SpruCAM X MachineMaker app enables you to create a digital replica of your CNC machine within minutes. Moreover, it provides access to an extensive collection of 3D machine models and post processors.

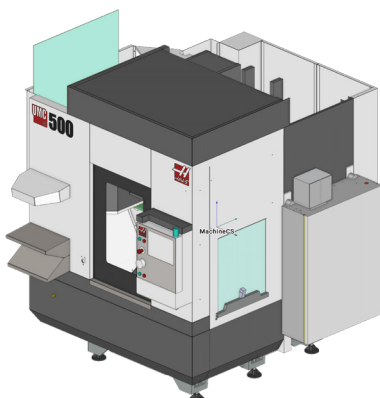

CAD in CAM

SpruCAM X includes a full-featured 3D CAD module that allows the engineer to work in a familiar, natural environment both when modeling and programming CNC machines and industrial robots. SpruCAM X is an integral, seamless CAD/CAM solution where the 3D CAD model format is native to the CAM module. As a result, the transfer of geometric and other features from the 3D model of the part to and from the CAM module of the system is done without any loss of information or significant time.

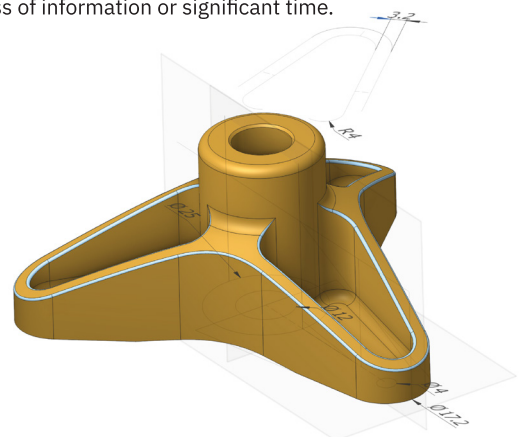

SprutCAM X Platform

One platform for both worlds

With a single technology solution, programming both CNC machines and industrial robots becomes effortless.

Efficiency and Safety

SprutCAM X optimizes toolpaths in real-time based on the current state of the material (stock), reducing unnecessary movements and cutting time for improved efficiency.

Technological independence

Our platform does not rely on external CAD/CAM modules or algorithms, everything is proprietary, including the CAD data translators.

Phenomenal interactivity

Easily adjust the number of passes, direction, or depth, and change the machining strategy on the fly using the familiar drag-and-drop technology.

Innovations for your manufacturing

We are pioneers in the field of Machine-Aware programming, a technology that considers the movement capabilities and limitations of machines and robots at the initial programming stage.

Unique user experience and interface

We strive to create a workflow that is intuitive and effortless for users. UI/UX designers play a crucial role in the development of SprutCAM X software, as they are responsible for creating intuitive and user-friendly interfaces for the software.

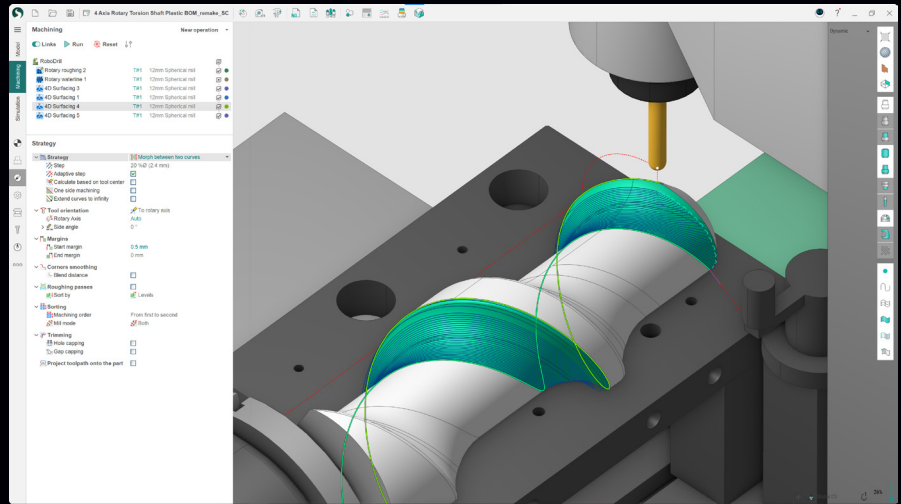

Why SprutCAM X

- Streamlined CNC programming workflow
- Machine aware toolpath calculation
- Advanced rest material handling
- Watch how the workpiece is machined during every operation
- Full machine simulation
- Equipment safety
- G-code simulation and verification
- You do not need separate software for G-code verification

What we make

Our flagship product, SprutCAM X, is a widely used CAD/CAM system for programming both CNC machines and industrial robots across various industries and countries. The system's unique feature is a single interface that creates a natural environment for engineers, making complex technological tasks more manageable.

We also offer an extensive network of resellers who provide swift technical support worldwide. Our customers range from small shops with a dozen CNC machines to large international corporations with fully automated production. We strive to provide all of them with the best digital tools at an affordable price.

Who we are

With a deep understanding of industry needs, SprutCAM Tech develops powerful software for programming CNC machines and industrial robots, enabling customers to seamlessly transition from CAD to finished parts with the fastest turnaround time in the industry. With 30 years of experience, we design a user-friendly interface that simplifies and accelerates shop floor tasks. Inspired by nature, our team creates a natural CAD/CAM environment for the next generation of makers.



Authorised Reseller

N C Tools

Suite 16, 31 South Corporate Avenue
Rowville VIC 3178 Australia

w: www.nctools.com.au e: sales@nctools.com.au